

Narrowbanding

An Implementation Guide for Technicians

Updated with the latest
FCC rules as of June 2010

FCC Schedule

- This process started in the mid 1990s.
- Covers VHF High-band (150-160 MHz) and UHF (450-470 MHz)
- Previous FCC ruling was in 2003 with the following dates:
 - January 1, 2011
 - No new licenses for wideband channels unless part of an existing system.
 - No new wideband capable equipment imported or manufactured.
 - January 1, 2013
 - All systems converted to narrowband operation.
- Latest FCC ruling June, 2010, relaxed the equipment availability date to January 1, 2013. Wideband equipment can continue to be manufactured and imported until then. No other requirements have been relaxed.
- Exceptions
 - Paging only channels such as 152.0075 MHz are excluded.
 - Non-Part 90 channels, Marine Channels, Part 22 channels

Implementation Schedule

No more new wideband system licenses or modifications

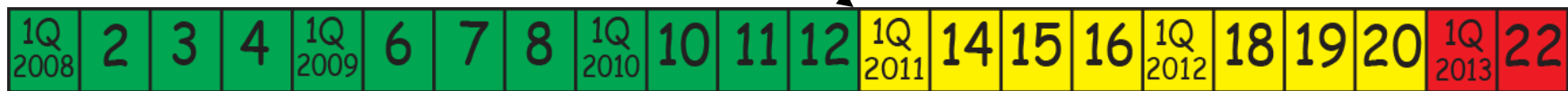

You are here!

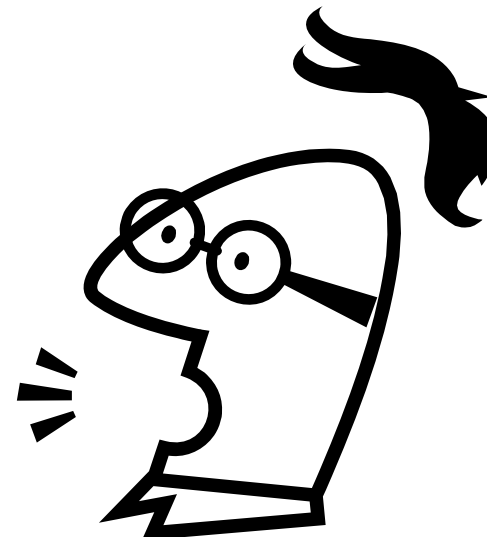

What's the big deal?

- A big deal or not?
- Big Deal
 - Existing equipment not narrowband capable
 - Areas where coverage is not adequate
- No Big Deal
 - Existing equipment narrowband capable
 - Coverage good to excellent in all areas

Narrowband Channel Plan

- VHF Channel Plan
 - 7.5 kHz channel spacing
 - 11.25 kHz occupied bandwidth
 - It doesn't all fit
- UHF Channel Plan
 - 12.5 kHz channel spacing
 - 11.25 kHz occupied bandwidth
 - It all fits
- What about 6.25 kHz?
 - Allowed now but no mandatory date set

Current Situation

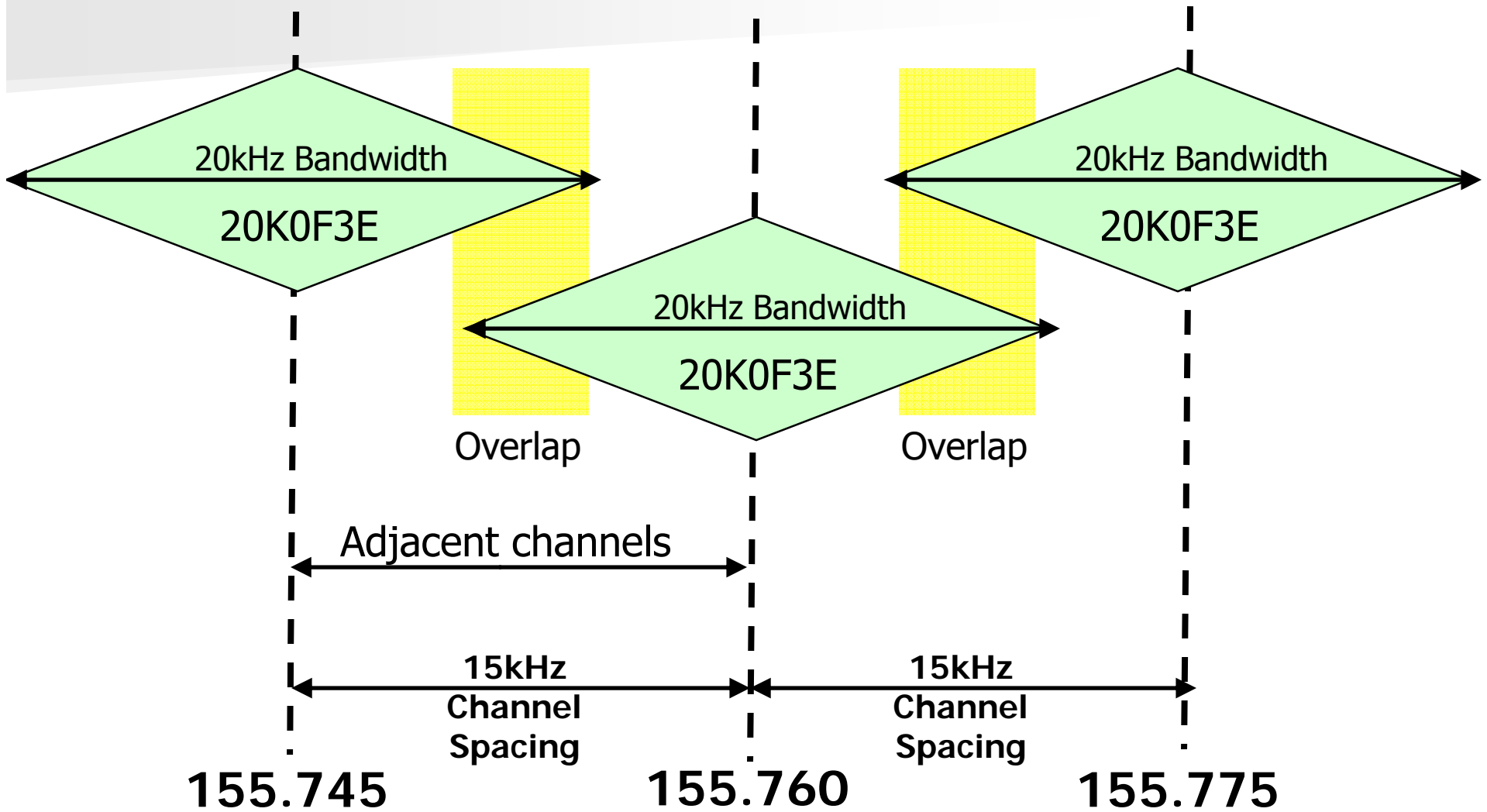

Interim Period

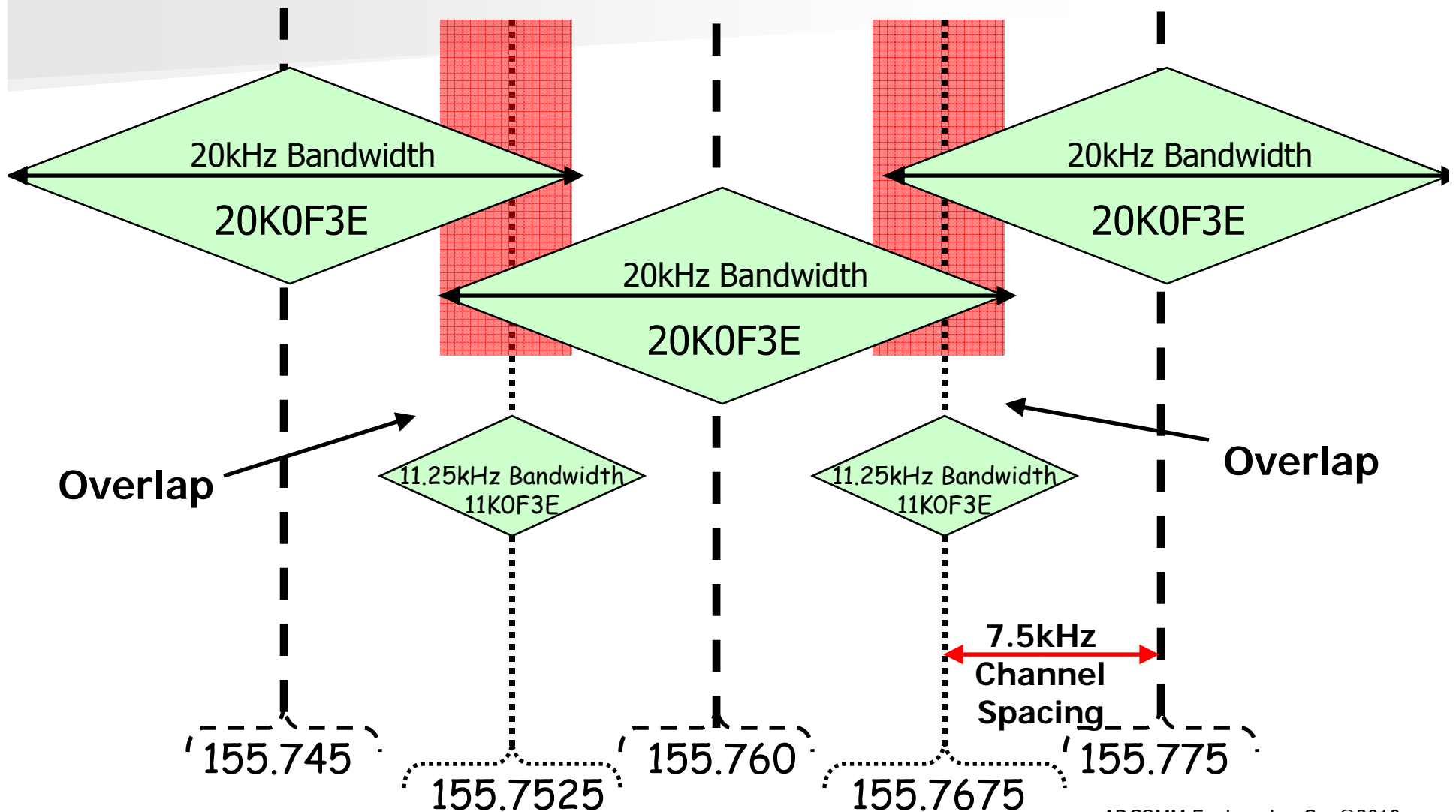

After 2013 – Analog Modulation

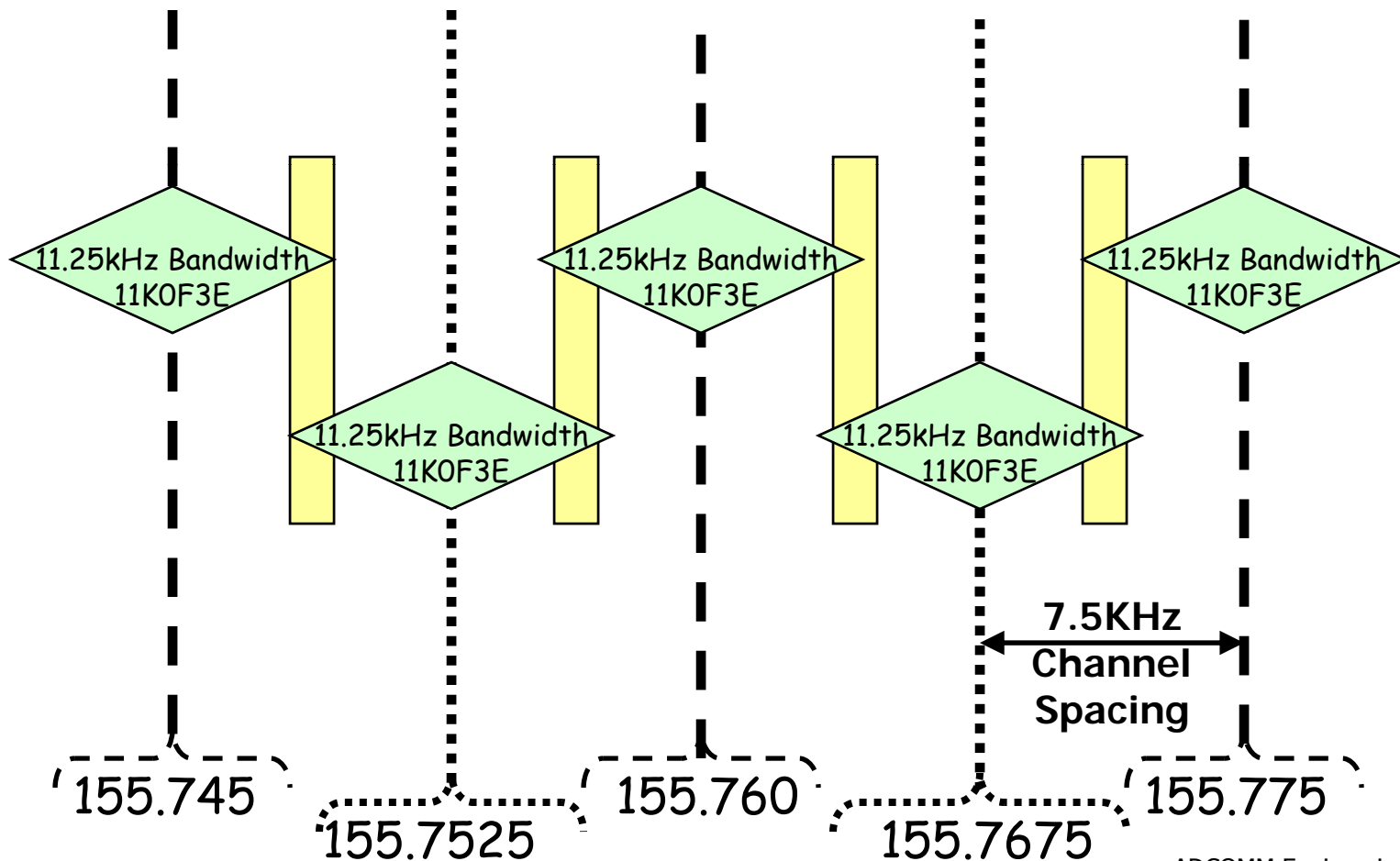

After 2013 – Narrowband Digital

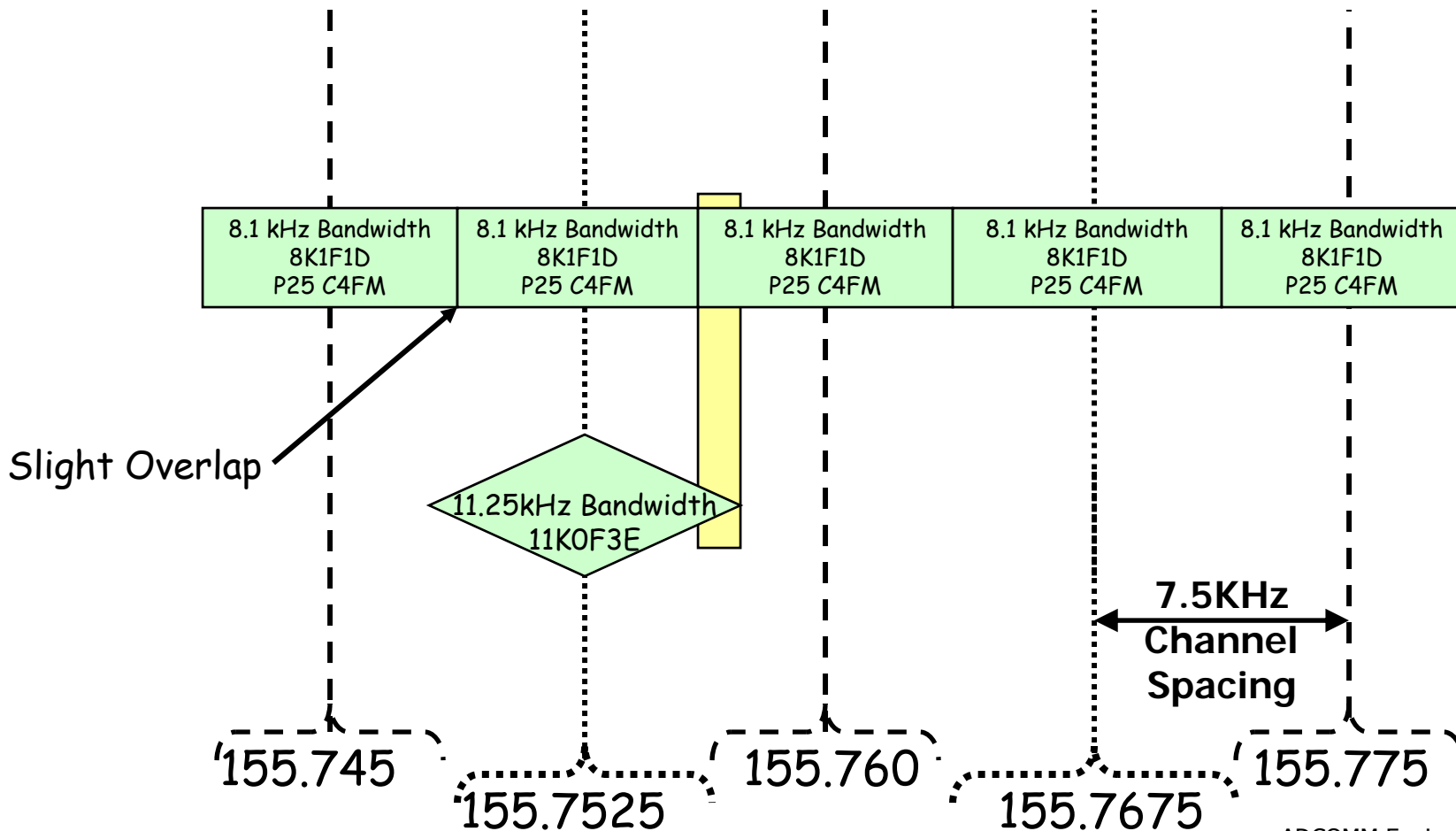

Equipment Compatibility

- Changing to narrowband equipment using existing channels should be ok.
- Not all equipment can use the new narrowband channels.
 - Different models of equipment have different frequency steps (e.g., 15 kHz, 7.5 kHz, 5 kHz, 2.5 kHz)
 - Only radios with 2.5 kHz steps or .5 kHz steps will work on all narrowband channels

Equipment Compatibility

■ Transmitters

- 2.5 kHz deviation
- Improved frequency control
- FCC Requires
 - VHF
 - Mobile 5.0 ppm (750 Hz worst case)
 - Base 2.5 ppm (325 Hz worst case)
 - UHF
 - Mobile 2.5 ppm (1175 Hz worst case)
 - Base 1.5 ppm (705 Hz worst case)
- Radios likely not work well at maximum frequency error. Purchase radios with better tolerances than the FCC requires.

Equipment Compatibility

■ Receivers

- Adjacent channel protection may not be as good as before.
 - Brand A – 30 kHz 78 dB 12.5 kHz 67 dB
 - Brand B – 30 kHz 70 dB 12.5 kHz 60 dB
 - Brand C – 30 kHz 80 dB 12.5 kHz 63 dB
 - Brand D – 30 kHz 80 dB 12.5 kHz 80 dB
- Be careful when checking out specifications
- Hum and noise generally not as good as with wideband

Equipment Compatibility

■ Receivers

- Sensitivity may be better, worse, or the same depending on the receiver design.
- Other noise effects such as ignition, fast fading, etc. can be magnified in narrowband receivers.

■ Comanding

- Some vendors have an audio comanding option. These are generally vendor proprietary and should not be used in public safety for interoperability.

Coverage

- Radio coverage will change.
 - Generally reduced for analog systems
 - May remain consistent if converting to digital
 - Users may not notice the coverage reduction if coverage is good or primarily terrain limited
 - Best “guess” is coverage reduced by 6 dB
 - Due to wide variation in user equipment coverage may change more for some users

Coverage

- Why does coverage change?
 - Transmitter power is the same
 - RF levels at any given location are not affected by the transmitted deviation
 - Some receive sensitivities may be increased
 - Narrower IF filters means less noise
 - Less noise = better signal-to-noise ratio
 - Seems like coverage should get better!

Coverage

- Coverage changes because the modulation changes
 - Deviation is the key for FM
 - Commercial FM – 75 kHz
 - Old 2-way FM (1950s) – 15 kHz
 - Existing FM – 5 kHz
 - Narrowband – 2.5 kHz
 - As the deviation gets less
 - Quieting gets less (ability to overcome noise)
 - Capture effect gets less
 - Audio recovery more difficult

Coverage

- Coverage should be measured using audio quality not signal strength
- Reduced range based on Circuit Merit 3.0-3.4 as the desired audio recovery
- It is all based on Modulation Index
 - Modulation Index ($\beta = \text{Dev}/\text{Max Audio}$)
 - Commercial FM $\beta = 5$
 - 5 kHz deviation $\beta = 1.67$
 - 2.5 kHz deviation $\beta = .69$

Coverage

- Coverage terrain limited

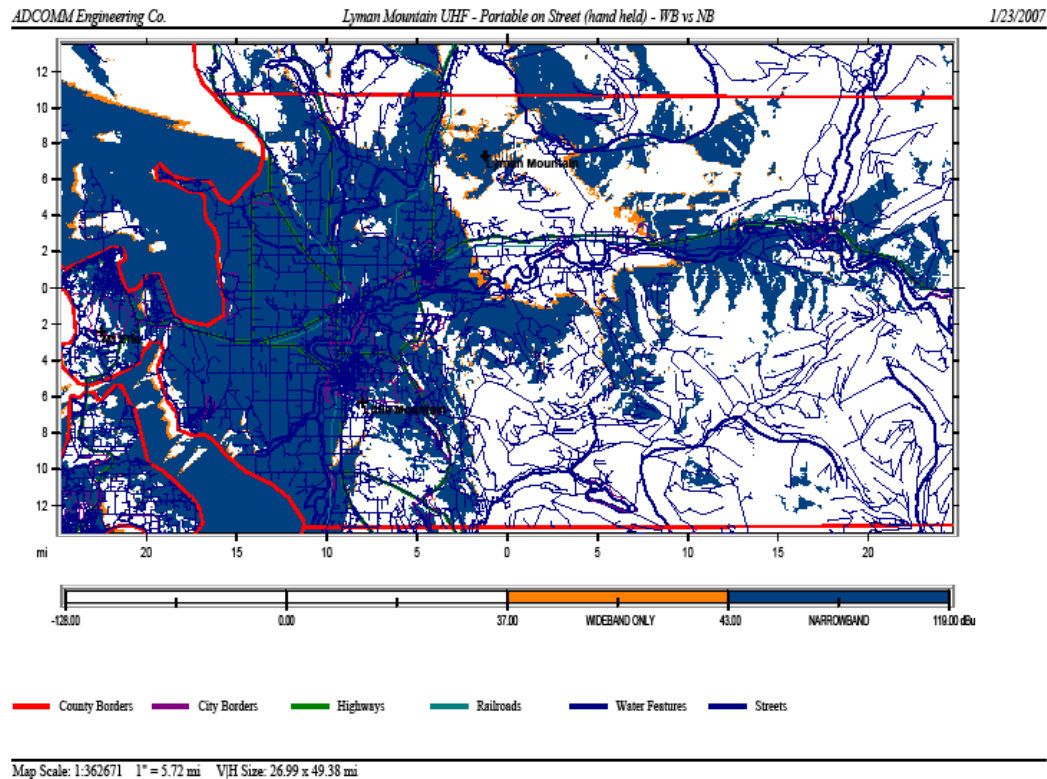

Coverage

- Coverage signal strength limited

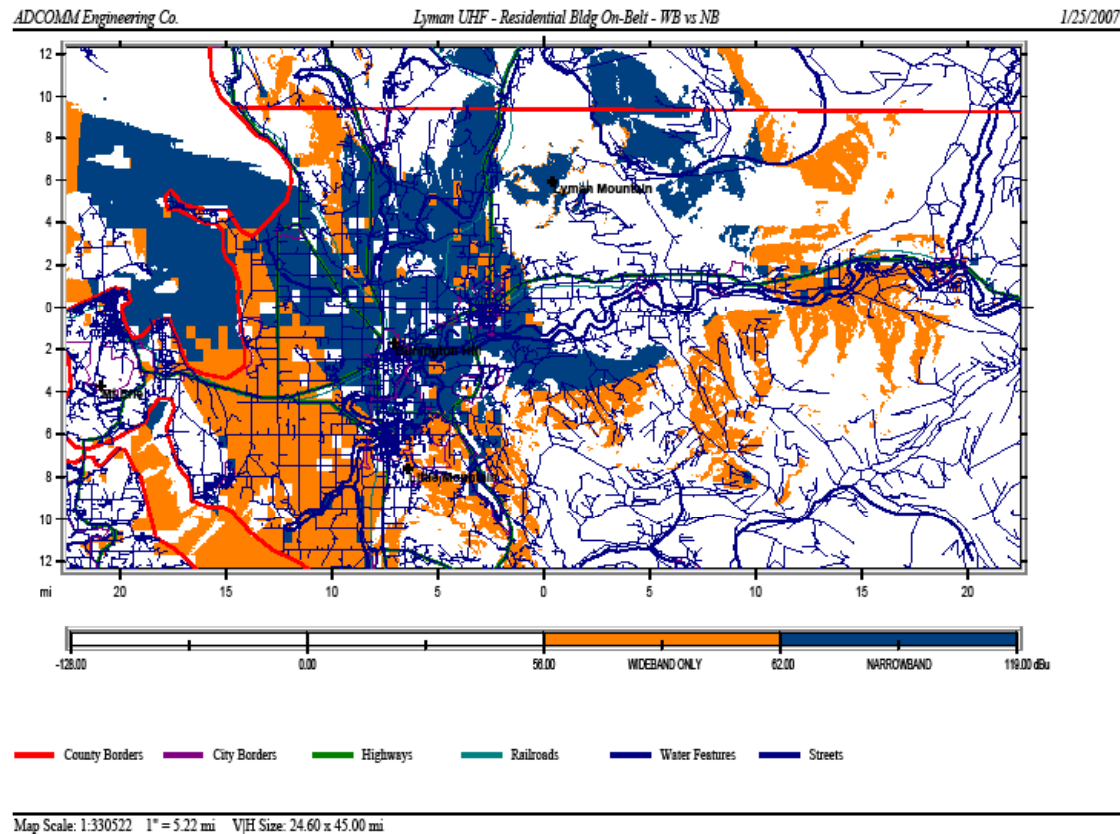

Coverage

■ Additional Examples

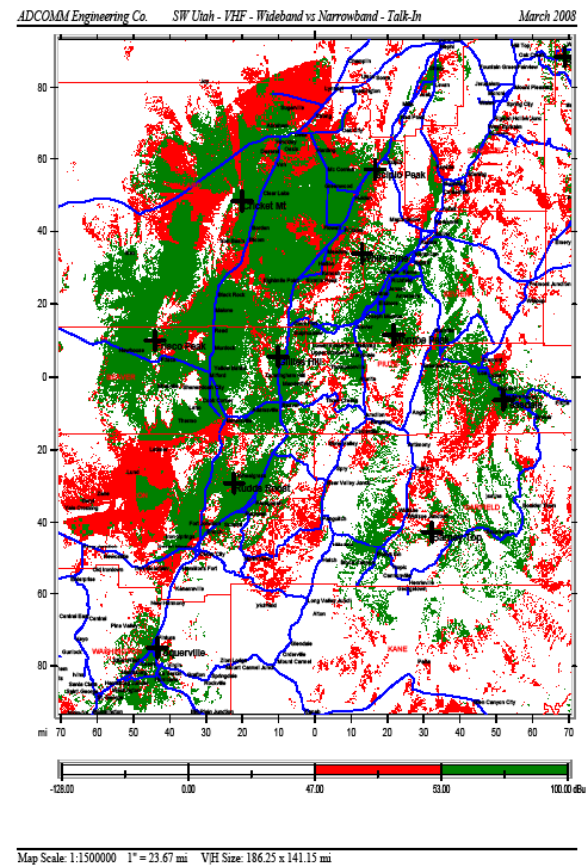
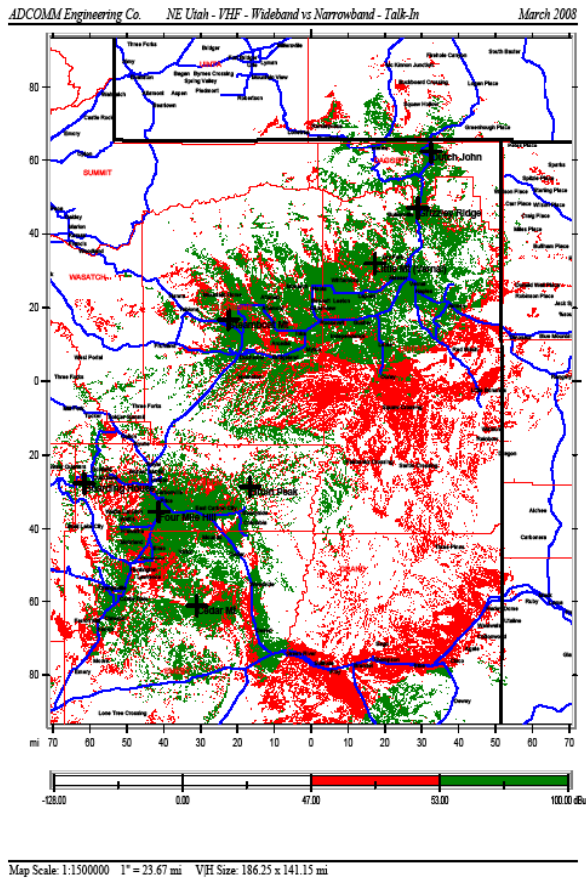

Implementation

- System adjustments
 - More critical, frequency, deviation, etc.
 - Service Monitors may not have right scale for 2.5 kHz deviation
 - CTCSS deviation 300 Hz or so
- Consider using some type of audio processing for repeat audio and transmitted audio to make audio more consistent. (See ADCOMM presentation from last year on audio processing.)

Implementation

- Coordination with neighbors and other users.
 - Wide/narrowband equipment will not work effectively together.
 - When will your neighbors change?
 - What about wide area mutual aid channels such as LERN, Rednet, HEAR, WHEER?
 - Other users such as public works, etc.
 - How will you program your radio? Dual sets of channels for wide and narrowband?

Implementation

- Evaluate your system and user equipment.
- Evaluate your coverage and estimated new coverage.
- Determine if new sites are required. If so, start site location and development.
- Coordinate with neighbors to develop coordinated transition plan.
- Work with users to determine when they can upgrade their equipment. Costs could be significant.

Implementation

- Develop a coordinated transition plan.
- Procure equipment. Carefully compare vendor specifications.
- Consider if initial installation will be in wideband mode or if slash cut will be required.
- Develop schedule for user equipment replacement. Resources for subscriber unit installations may be limited due to rebanding and volume of work required.
- Pick a cut over date and develop final cut over plan.
- Now you are talking narrowband.

Considering Digital?

- Going digital may mitigate some coverage issues.
- Going digital is a major decision with many ramifications including
 - Cost
 - Maintenance
 - Interoperability
 - Functionality
- Subject for another presentation!

Questions?

Thank you!

Joe Blaschka Jr. PE

j.blaschka@adcomm911.com

425-821-8827

www.adcommeng.com